

TUBULAR TYPE LEVEL GAUGE

NL SERIES – With Protection Support Rod SL SERIES – With Protection Support Pipe

The tubular glass type is a simplest liquid level gauge for using in the pressure rating of 10 kg/cm² or under. The center to center length are over 1.5 meter. The intermediary joint ring would be used. Gauge glass are made heat resistant borosilicate.

Technical Data

- Suitable Fluid:** Water, Oil, other chemical liquid
- Gauge Valve Material:** SS304, SS316, others available
- Gauge Tube Material:** Glass, P.V.C
- Seal Material:** Viton, Teflon available
- Gauge Valve Function:** With or Without ball check
- Max. Working Temperature:** 100°C
- Max. Working Pressure:** 4~7 kg/cm²
- Process Connection:** ½”~1½” Thread and Flange on request.
- Flange Rating:** JIS, ANSI, DIN available
- Drain Valve Connection:** standard ½”NPT(F); option available

Dimensions for NL Series

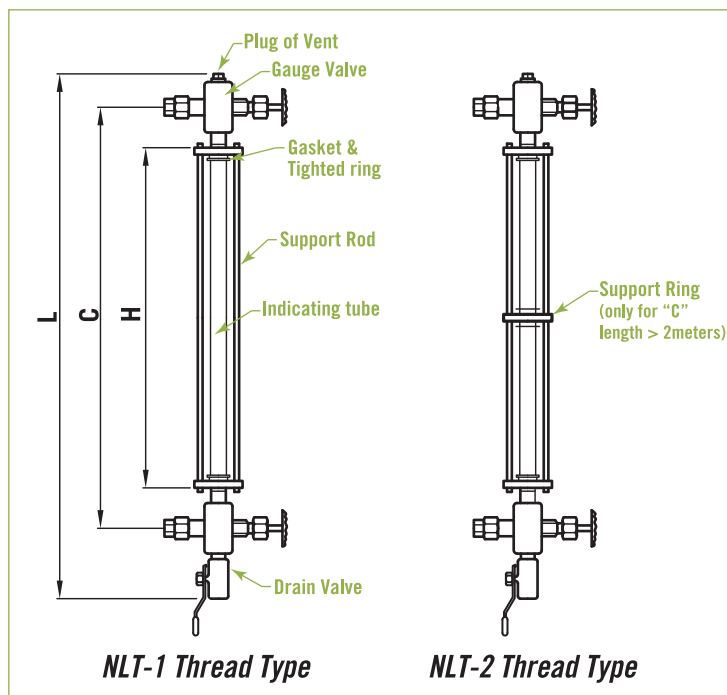

NLT-1 Thread Type

NLT-2 Thread Type

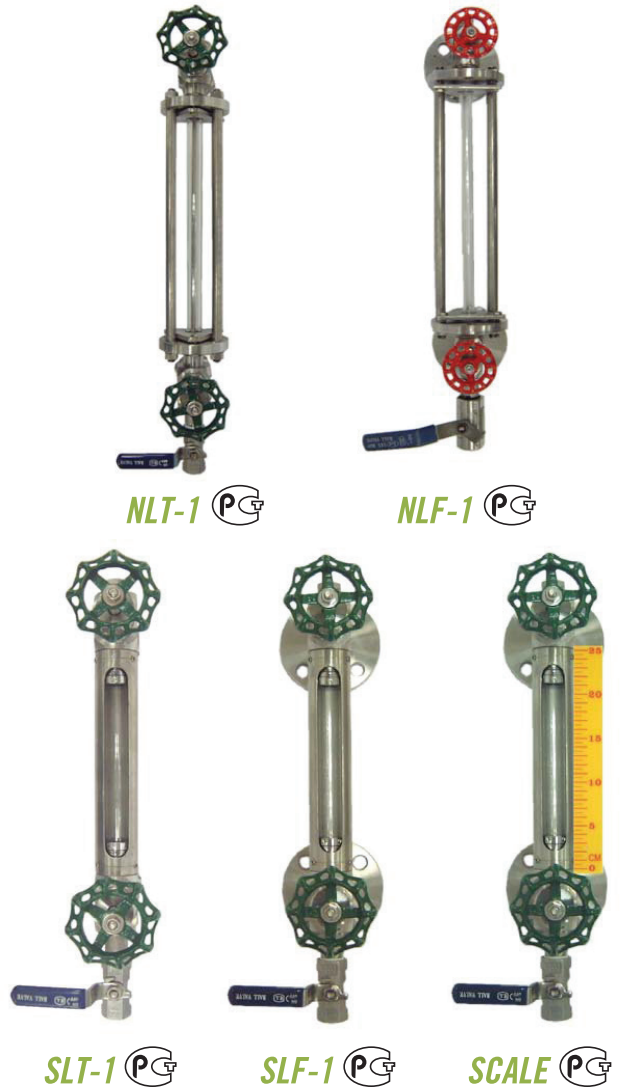

NLT-1

NLF-1

SLT-1

SLF-1

SCALE

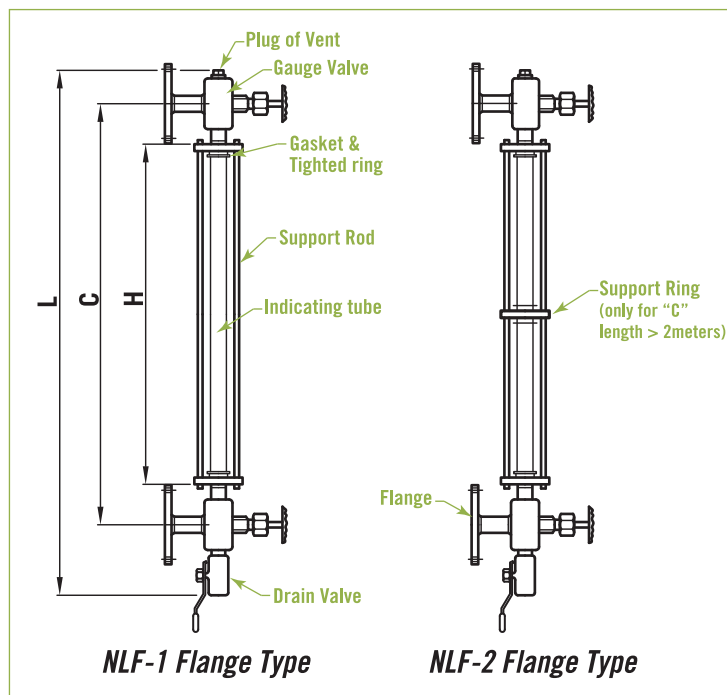

NLF-1 Flange Type

NLF-2 Flange Type

mm Item	L	C	H	Section
1	400	300	200	1
2	600	500	400	1
3	900	800	700	1
4	1200	1100	1000	1
5	1300	1200	1100	1
6	1600	1500	1400	2
7	1900	1800	1700	2
8	2100	2000	1900	2

NOTE. The "C" dimension can be made by requirement of customer. Option available.

Dimensions for SL Series

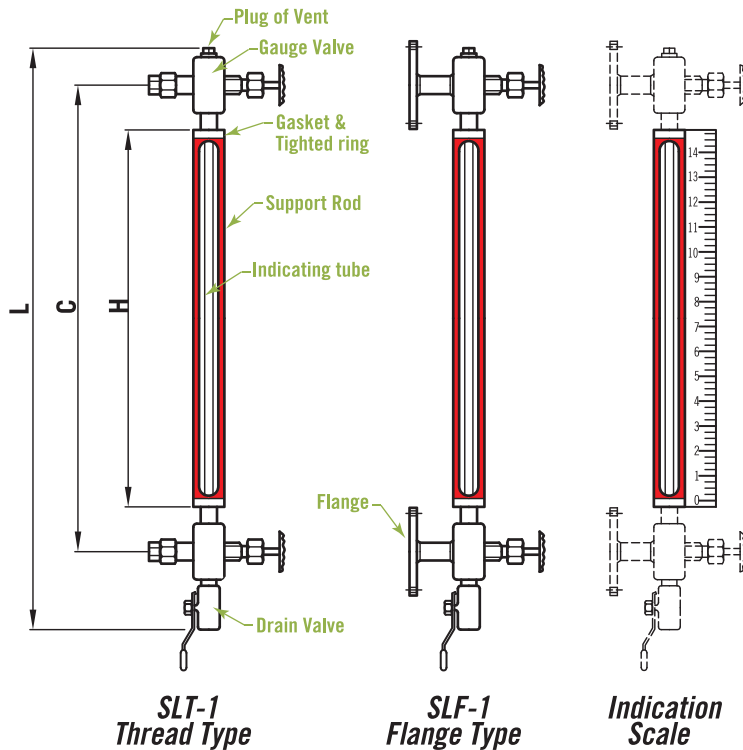

Item	mm	L	C	H	Section
1		400	300	200	1
2		600	500	400	1
3		900	800	700	1
4		1100	1000	900	1
5		1300	1200	1100	1
6		1600	1500	1400	2
7		1900	1800	1700	2
8		2100	2000	1900	2

NOTE. The "C" dimension can be made by requirement of customer. Option available.

Ordering Information

Model	NLT-1	with protection support rod; Thread type (section 1)
	NLT-2	with protection support rod; Thread type (section 2)
	NLF-1	with protection support rod; Flange type (section 1)
	NLF-2	with protection support rod; Flange type (section 2)
	SLT-1	with protection support pipe; Thread type
	SLF-1	with protection support pipe; Flange type
	Code	Connection Size
	Thread	(A) 1/2"NPTM (B) 1/2"NPTF (C) 3/4"NPTM (D) 3/4"NPTF (E) option
	Flange	(F) 1/2" JIS 10K (G) 3/4" JIS 10K (H) 1" JIS 10K (I) 1/2" ANSI 150# (J) 3/4" ANSI 150# (K) 1" ANSI 150# (L) option
	Code	Gauge Valve Material
		(1) SS304 (2) SS316 (3) option
	Code	Gauge Tube Material
		(1) Glass (2) PVC
	Code	Seal Material
		(1) Viton (2) Teflon
	Code	The Function of Gauge Valve
		(A) With Ball Check (B) Without Ball Check
	Code	Drain Valve Connection
		(1) 1/2"NPTF, standard (2) Option
	Code	Center to Center Length (C to C)
		Please directly fill out the length you required.
	Code	Scale Plate
	A	Yes
	B	Without
	Complete Ordering Code	